

=====

Phase 5.13
Full and Half Unit & Half, half unit bodies of 0 to 10 spaces

Dr. Sant Kumar Kapoor,
Ved Ratan

=====

Abstract

Vedic knowledge systems are availing ‘Full and Half Unit & Half, half unit bodies of 0 to 10 spaces’ and transcendence within origin of 3-space as compactified formats of four onward spaces, and have exhaustively covered the existence phenomenon of universe.

1. Table of Full and half unit and half, half unit bodies of 0 to 10 spaces content

	D1	D2	D3	D4	D5	D6	D7	D8	D9	D10
	-4	0	4	8	12	16	20	24	28	32
	H1	H2	H3	H4	H5	H6	H7	H8	H9	H10
	2	6	10	14	18	22	26	30	34	38
	h1	h2	h3	h4	h5	h6	h7	h8	h9	h10
	3	7	11	15	19	23	27	31	35	39

2. Number values of 20 full and half unit bodies and of 1 to 10 spaces content

The 30 number values ‘of 20 full and half unit bodies and of 1 to 10 spaces content’, in sequential ascending order are

(-4, 0, 2, 3, 4, 6, 7, 8, 10, 11, 12, 14, 15, 16, 18, 19, 20,
 22, 23, 24, 26, 27, 28, 30, 31, 32, 34, 35, 36, 38, 39)

The numbers ‘-3, -2, -1, 1, 5, 9, 13, 17, 21, 25, 29, 33, 37’ are jumped over.

3. Sathapatya of 13 jumped over numbers

SN	Number	Sathapatya
1	-3	h -1
2	-2	H -1
3	-1	h - ½
4	1	h ½
5	5	h 1½
6	9	h 2½
7	13	h 3½
8	17	h 4½
9	21	h 5½
10	25	h 6½
11	29	h 7½
12	33	h 8½
13	37	h 9½

The values (-4 to 39) make values range '44' parallel to TCV (परमव्योम्) / Transcendental space. Value 39 is parallel with factors of values range 1 to 21. This is the basis parallel with transcendence of transcendental content flow through ray of Sun in 8 directional frame from East / पूर्व Purva, TCV (पूर्व Purva) = 21.

4. Sequential transcendence through origin of 3-space along compactified range of origins of 4-space onwards

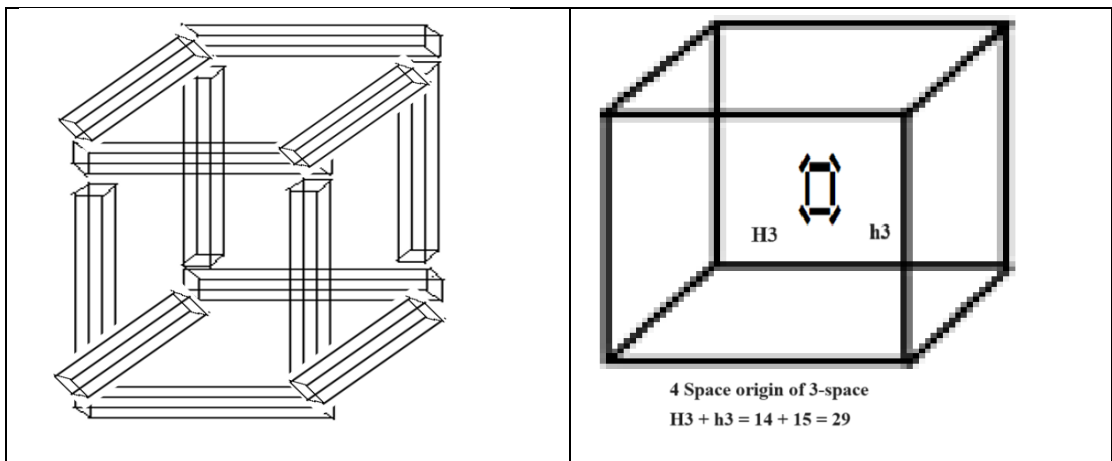

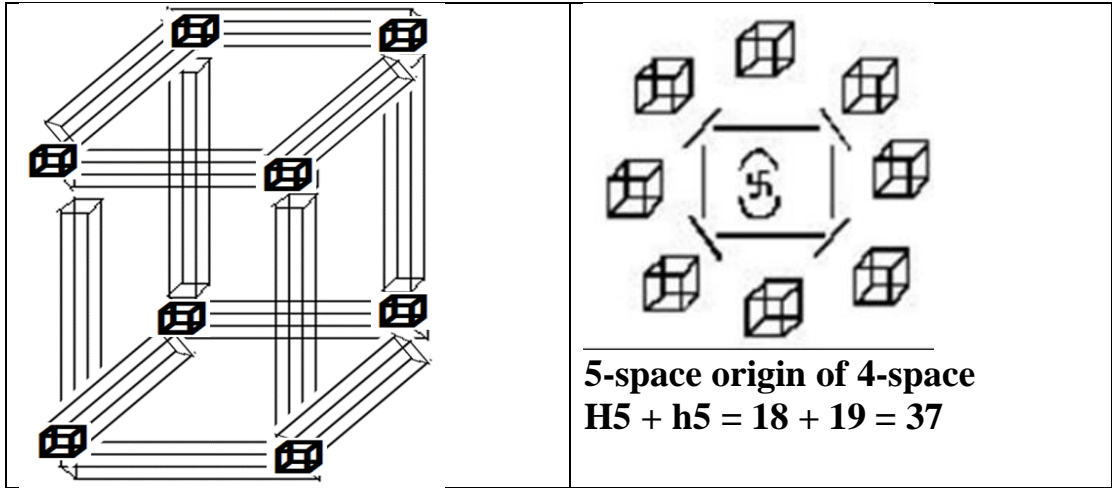

Table 1

Full unit bodies	H1 (-1, 0, 1, 2) 2	H2 (0, 1, 2, 3) 6	H3 (1, 2, 3, 4) 10	H4 (2, 3, 4, 5) 14	H5 (3, 4, 5, 6) 18	H6 (4, 5, 6, 7) 22
Half unit bodies	h1 (0, ½, 1, 1 ½) 3	h2 (1, 1 ½, 2, 2 ½) 7	h3 (2, 2 ½, 3, 3 ½) 11	h4 (3, 3 ½, 4, 4 ½) 15	h5 (4, 4 ½, 5, 5 ½) 19	h6 (5, 5 ½, 6, 6 ½) 23
Pairing Value	H1h1 2, 3 Origin of 0-space	H2h2 6, 7 Origin of 1-space	H3h3 10, 11 Origin of 2-space	H4h4 14, 15 Origin of 3-space	H5h5 18, 19 Origin of 4-space	H6h6 22, 23 Origin of 5-space

Vedic Mathematics reach is blissfully parallel with the existence phenomenon manifestation of transcendental content flow from orb of the Sun through rays of the Sun. The sequential देहांतरन Dehantaran of जीव आत्मा Jeev Atma / Being phenomenon is of Sathapatya (geometric format).

Table 2

Translation of four folds along five fold ranges

First Five fold transcendental range (Tr1)	(1, 2, 3, 4, 5)	(1, 2, 3, 4) H3	(2, 3, 4, 5) H4
Second Five fold transcendental range (Tr2)	(2, 3, 4, 5, 6)	(2, 3, 4, 5) H4	(3, 4, 5, 6) H5
Third Five fold transcendental range (Tr3)	(3, 4, 5, 6, 7)	(3, 4, 5, 6) H5	(4, 5, 6, 7) H6
Fourth Five fold transcendental range (Tr4)	(4, 5, 6, 7, 8)	(4, 5, 6, 7) H6	(5, 6, 7, 8) H7
Fifth Five fold transcendental range (Tr5)	(5, 6, 7, 8, 9)	(5, 6, 7, 8) H7	(6, 7, 8, 9) H8
Sixth Five fold transcendental range (Tr6)	(6, 7, 8, 9, 10)	(6, 7, 8, 9) H8	(7, 8, 9, 10) H9
Seventh Five fold transcendental range (Tr7)	(7, 8, 9, 10, 11)	(7, 8, 9, 10) H9	(8, 9, 10, 11) H10

Table 3

Translation of five folds along six folds ranges

First six fold self referral range (sr1)	(1, 2, 3, 4, 5, 6)	(1, 2, 3, 4, 5) (tr1)	(2, 3, 4, 5, 6) (tr2)
Second six fold self referral range (sr2)	(2, 3, 4, 5, 6, 7)	(2, 3, 4, 5, 6) (tr2)	(3, 4, 5, 6, 7) (tr3)
Third six fold self referral range(sr3)	(3, 4, 5, 6, 7, 8)	(3, 4, 5, 6, 7) (tr3)	(4, 5, 6, 7, 8) (tr4)
Fourth six fold self referral range (sr4)	(4, 5, 6, 7, 8, 9)	(4, 5, 6, 7, 8) (tr4)	(5, 6, 7, 8, 9) (tr5)
Fifth six fold self referral range (sr5)	(5, 6, 7, 8, 9, 10)	(5, 6, 7, 8, 9) (tr5)	(6, 7, 8, 9, 10) (tr6)
Sixth six fold self referral range (sr6)	(6, 7, 8, 9, 10, 11)	(6, 7, 8, 9, 10) (tr6)	(7, 8, 9, 10, 11), (tr7)
Seventh six fold self referral range (sr7)	(7, 8, 9, 10, 11, 12)	(7, 8, 9, 10, 11) (tr7)	(8, 9, 10, 11, 12) (tr8)

Conclusion

Great are our ancestors. We, the present generation, is held up in our mental state. We are highly thankful of our ancestors for preserving Ancient Wisdom scriptures for us. Let us be parallel with it. Let us be enlightened. Let us update our comprehension. Let us be parallel with ancient wisdom.

May 13, 2024